

Technical Data Sheet
High Power LED – 1W**EHP-A07/SUG01H-P01/TR****Features**

- Feature of the device: small package with high efficiency
- Typical view angle: 120°
- Typical light flux output: 45 lm @ 350mA.
- ESD protection.
- Soldering methods: SMT
- Grouping parameter: total luminous flux, dominant wavelength
- Optical efficiency: 34 lm/W.
- Thermal resistance (Junction to Heat sink): 20 °C /W
- The product itself will remain within RoHS compliant version.

**Applications**

- Interior and exterior automotive lighting (e.g. turn light and indicating sign)
- Warning signs applied
- Signal and symbol luminaries
- Portable light source
- Marker lights (e.g. steps, exit ways, etc.)

Materials

Items	Description
Reflector	Heat resistant polymer
Encapsulating Resin	Colorless clear resin
Electrodes	Ag plating
Die attach	Silver paste
Chip	InGaN

Dimensions

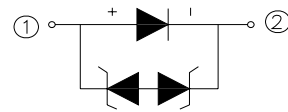
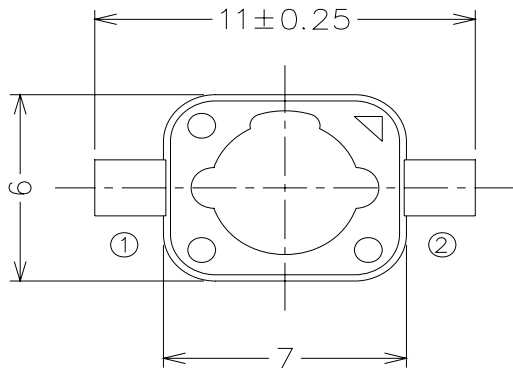

Polarity

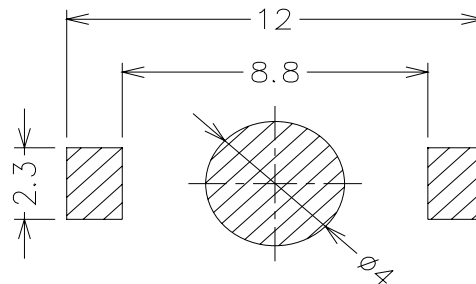
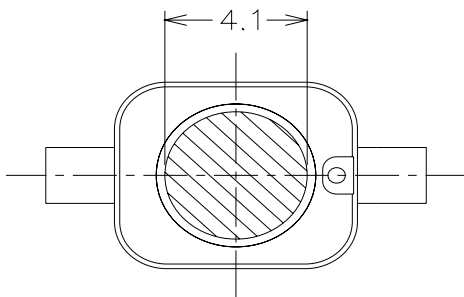
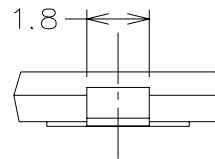
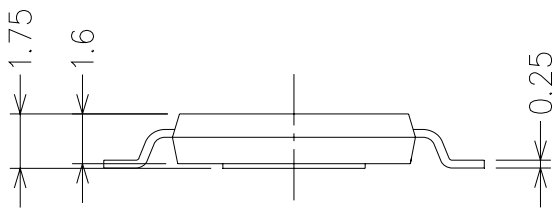

- Notes:**
1. Dimensions are in millimeters.
 2. Tolerances for fixed dimensions are $\pm 0.25\text{mm}$.

EHP-A07/SUG01H-P01/TR
Maximum Ratings ($T_{Ambient}=25^{\circ}C$)

Parameter	Symbol	Rating	Unit
DC Operating Current	I_F	350	mA
Pulsed Forward Current ⁽¹⁾	I_{PF}	500	mA
ESD Sensitivity	ESD	2000	V
Junction Temperature	T_j	125	$^{\circ}C$
Operating Temperature	$T_{op.}$	-40 ~ +100	$^{\circ}C$
Storage Temperature	$T_{stg.}$	-40 ~ +100	$^{\circ}C$
Power Dissipation	P_d	1	W
Junction To Heat-Sink Thermal Resistance	R_{th}	20	$^{\circ}C / W$

Electro-Optical Characteristics ($T_{Ambient}=25^{\circ}C$)

Parameter	Bin	Symbol	Min	Typ.	Max	Unit	Condition
Luminous Flux ⁽²⁾	J4	ϕ_v	39	----	45	lm	$I_F=350mA$
	J5		45	----	52		
	K1		52	----	60		
Forward Voltage ⁽³⁾	V2	V_F	3.25	----	3.55	V	
	V3		3.55	----	3.85		
	V4		3.85	----	4.15		
Wavelength ⁽⁴⁾	G1	λ_d	520	----	525	nm	
	G2		525	----	530		
	G3		530	----	535		
Viewing Angle ⁽⁵⁾	----	$2\theta_{1/2}$	----	120	----	deg	

Note. 1. $t_p \leq 100\mu s$, Duty cycle = 0.25

2. Luminous Intensity measurement tolerance: $\pm 10\%$.

3. Forward Voltage measurement tolerance: $\pm 0.1V$.

4. Wavelength measurement tolerance : $\pm 1nm$.

5. $2\theta_{1/2}$ is the off axis angle from lamp centerline where the luminous intensity is 1/2 of the peak value.

Typical Electro-Optical Characteristics Curves

Relative Spectral Distribution,
 $I_f=350\text{mA}$, $T_{\text{Ambient}}=25^\circ\text{C}$

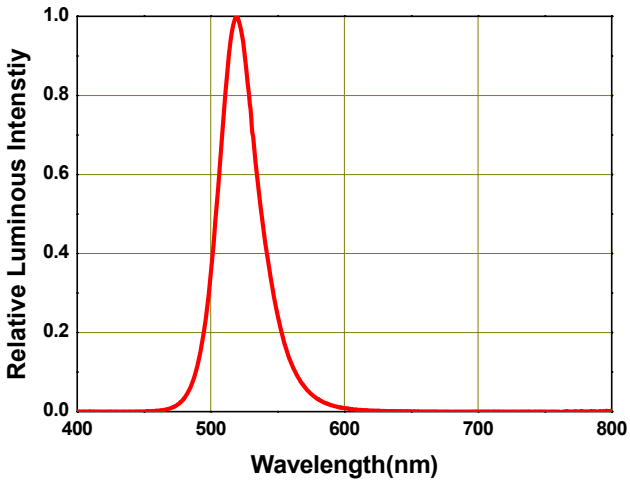

Forward Voltage vs Forward Current,
 $T_{\text{Ambient}}=25^\circ\text{C}$

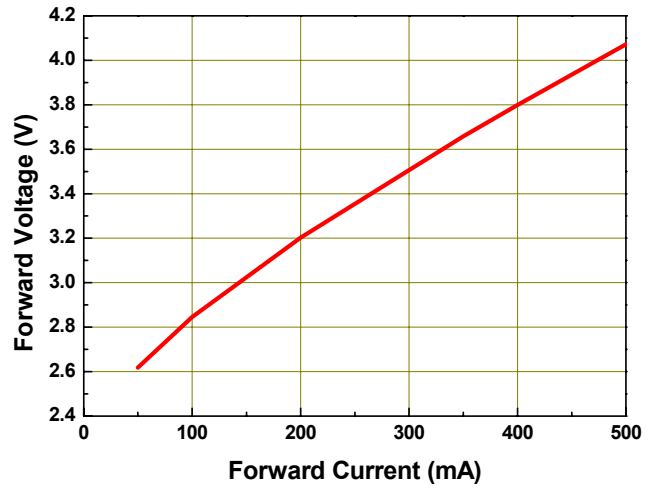

Relative Luminous Intensity vs Forward Current, $T_{\text{Ambient}}=25^\circ\text{C}$

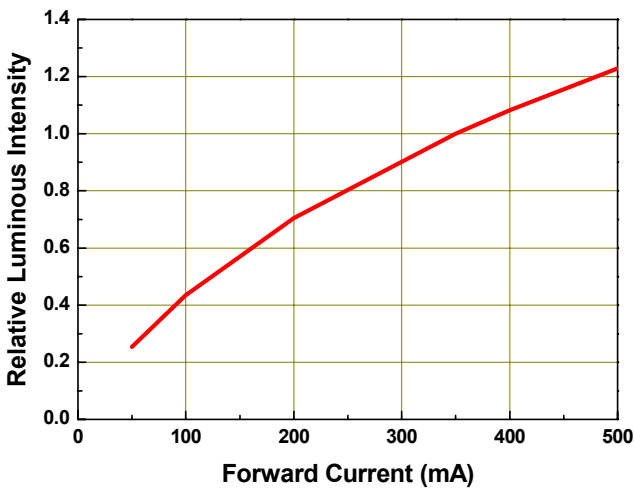

Ambient Temperature & Operating Current Derating based on $T_{\text{JMAX}} = 125^\circ\text{C}$

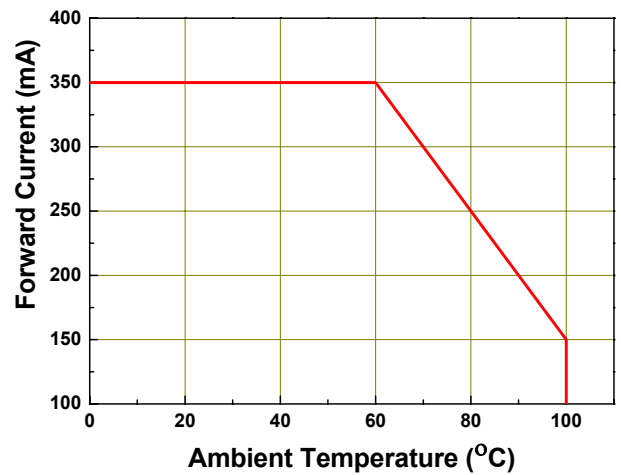

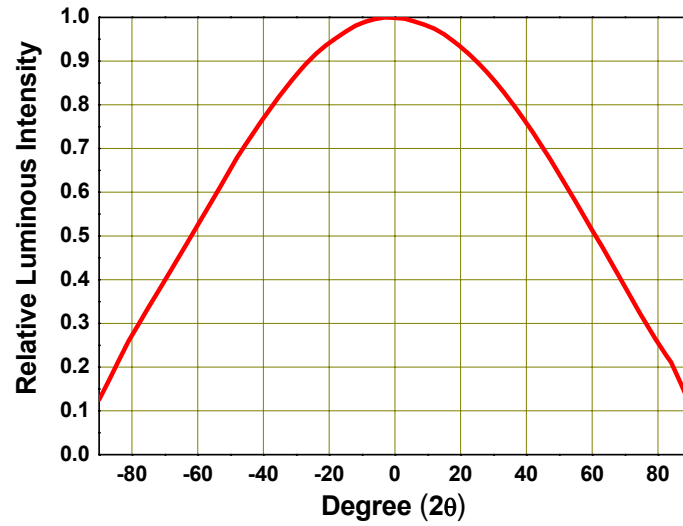
Typical Representative Spatial Radiation Pattern

Label explanation

- CPN: Customer's Production Number**
- P/N : Production Number**
- QTY: Packing Quantity**
- CAT: Luminous Rank**
- HUE: Dominant Wavelength, Color Rank**
- REF: Voltage Rank**
- LOT No: Lot Number**
- MADE IN TAIWAN: Production Place**

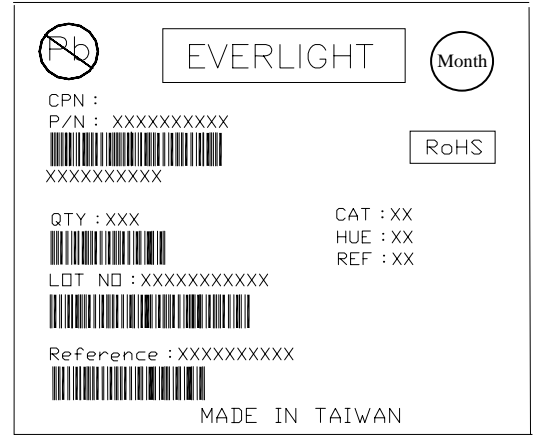

Reel Dimensions

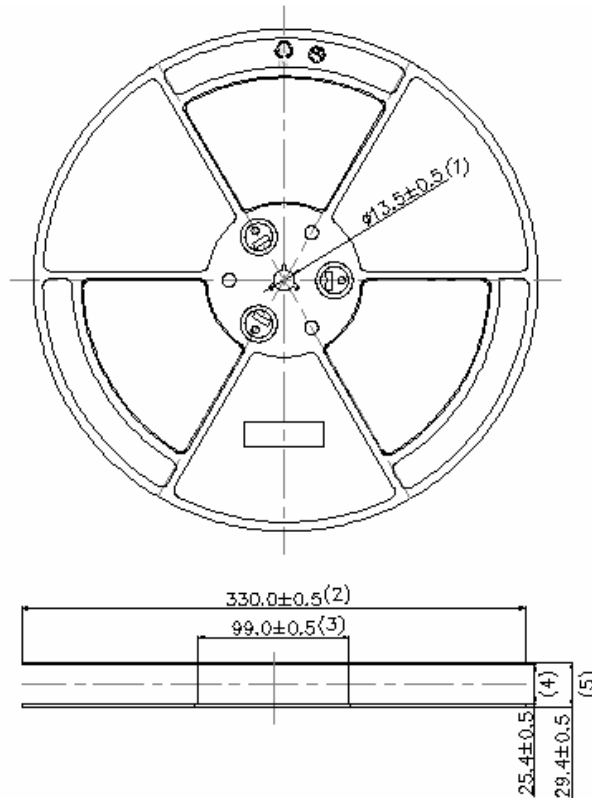

- Note: 1. Dimensions are in millimeters.**
- 2. Tolerances for fixed dimensions are ±0.1mm.**

EHP-A07/SUG01H-P01/TR

Carrier Tape Dimensions: Loaded quantity 800 PCS per reel

Progress Direction

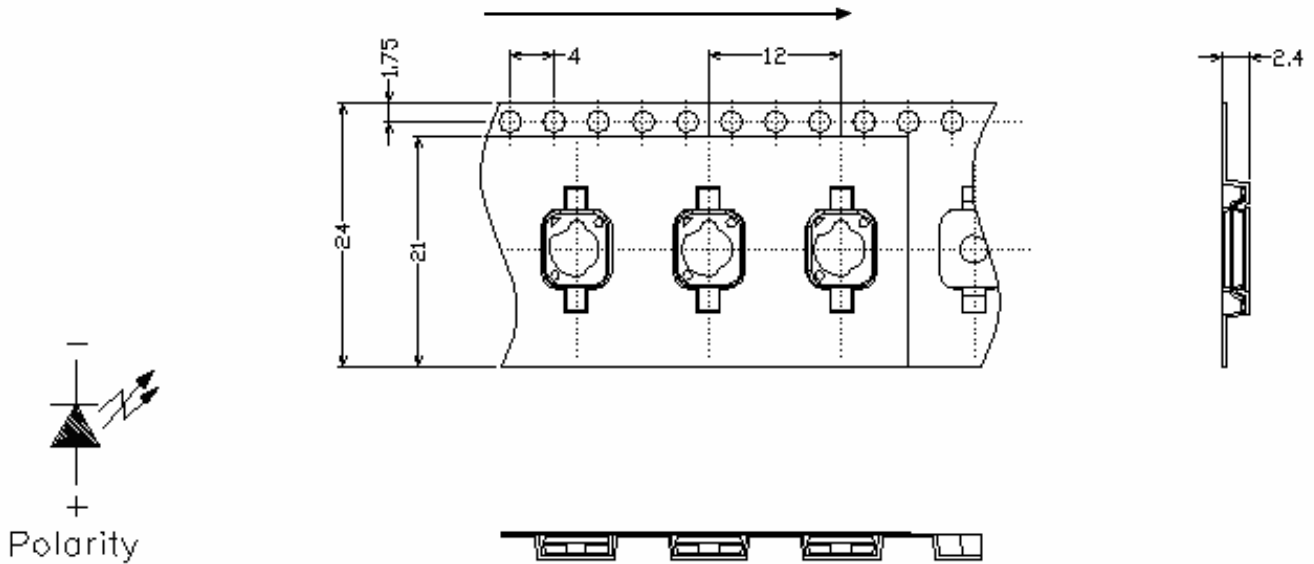

Note: 1. Dimensions are in millimeters.

2. Tolerances for fixed dimensions are $\pm 0.1\text{mm}$.

Moisture Resistant Packaging

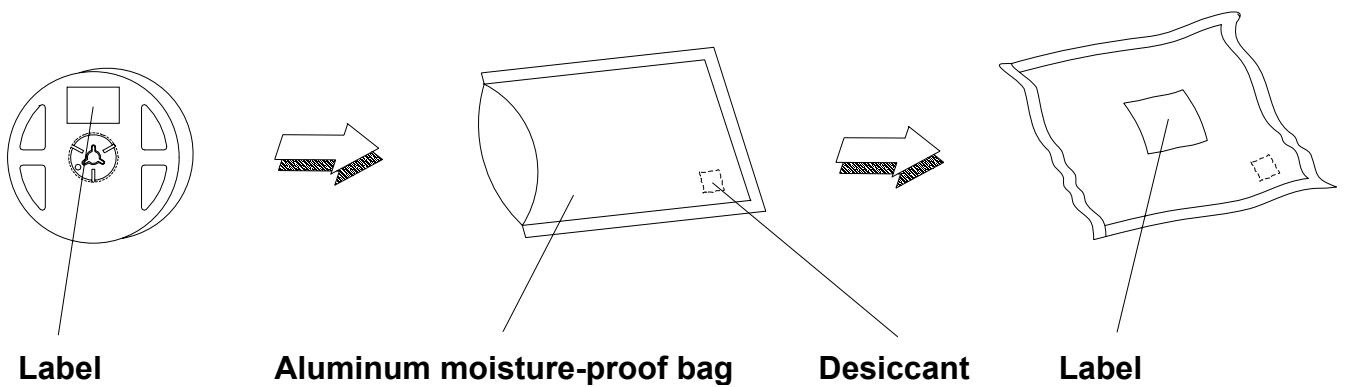

Precautions For Use**1. Over-current-proof**

Though EHP-A07 has conducted ESD protection mechanism, customers must not use the device in reverse and should apply resistors for extra protection. Otherwise, slight voltage difference may cause enormous current shift and burn out failure would happen.

2. Storage

- i. Do not open the moisture proof bag before the devices are ready to use.
- ii. Before the package is opened, LEDs should be stored at temperature less than 30°C and humidity less than 90%.
- iii. LEDs should be used within a year.
- iv. After the package is opened, LEDs should be stored at temperature less than 30°C and humidity less than 70%.
- v. LEDs should be used within 168 hours (7 days) after the package is opened.
- vi. If the moisture absorbent material (silicone gel) has faded away or LEDs have exceeded the storage time, baking treatment should be implemented based on the following the conditions: pre-curing at 60±5°C for 24 hours.

3. Thermal Management

- i. For maintaining the high flux output and achieving reliability, EHP-A07 series LEDs should be mounted on a metal core printed circuit board (MCPCB) or other kinds of heat sink with proper thermal connection to dissipate approximate 1W of thermal energy at 350mA operation.
- ii. Special thermal designs are also recommended to take in heat dissipation management, such as FR4 PCB on Aluminum with thermal vias or FPC on Aluminum with thermal conductive adhesive, etc.
- iii. Sufficient thermal management must be implemented. Otherwise, the junction temperature of dies might be over the limit at high current driving condition and LEDs' lifetime might be decreases dramatically.
- iv. For further thermal management suggestions, please consult Everlight Design Guide or local representatives for assistance.

4. Soldering Condition

For Reflow process

- a. EHP-A07 series are suitable for SMT process.
- b. Lead reflow soldering temperature profile

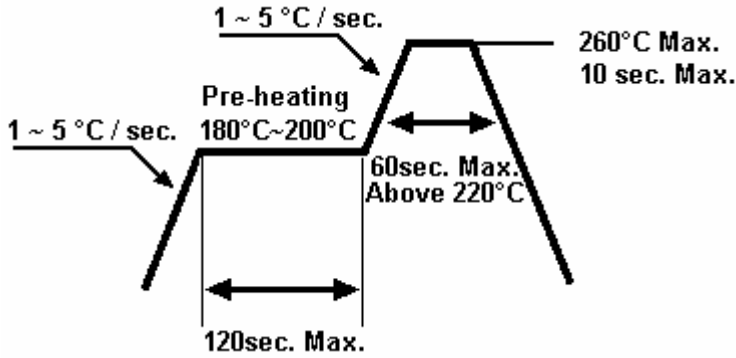

- c. Reflow soldering should not be done more than two times.
- d. In soldering process, stress on the LEDs during heating should be avoided.
- e. After soldering, do not warp the circuit board.

Revision History

Current version: **2009/01/13**

Previous version: N/A

Page	Subjects(major change in previous version)	Date of change